

PARKPOINTE

BOULEVARDS & PUBLIC SPACES



Team 1

students



Haotian Liu (HT)
Architectural
Designer



Luiza Albertini
Architectural
Designer



Michael Esteras
Political Science

faculty



Chris Pandolfi
Urban Designer



Mark Guslits
Architect



A photograph of a park with autumn trees and a person in the foreground, overlaid with a grid of semi-transparent circles. The scene is a lush green lawn with scattered fallen leaves, surrounded by trees with vibrant autumn foliage in shades of yellow, orange, and red. In the background, a paved path and a few people can be seen. The foreground features a person with long dark hair, wearing a dark jacket and a backpack, looking towards the trees. The entire image is covered with a grid of semi-transparent, light-colored circles.

Our observation...





Current state



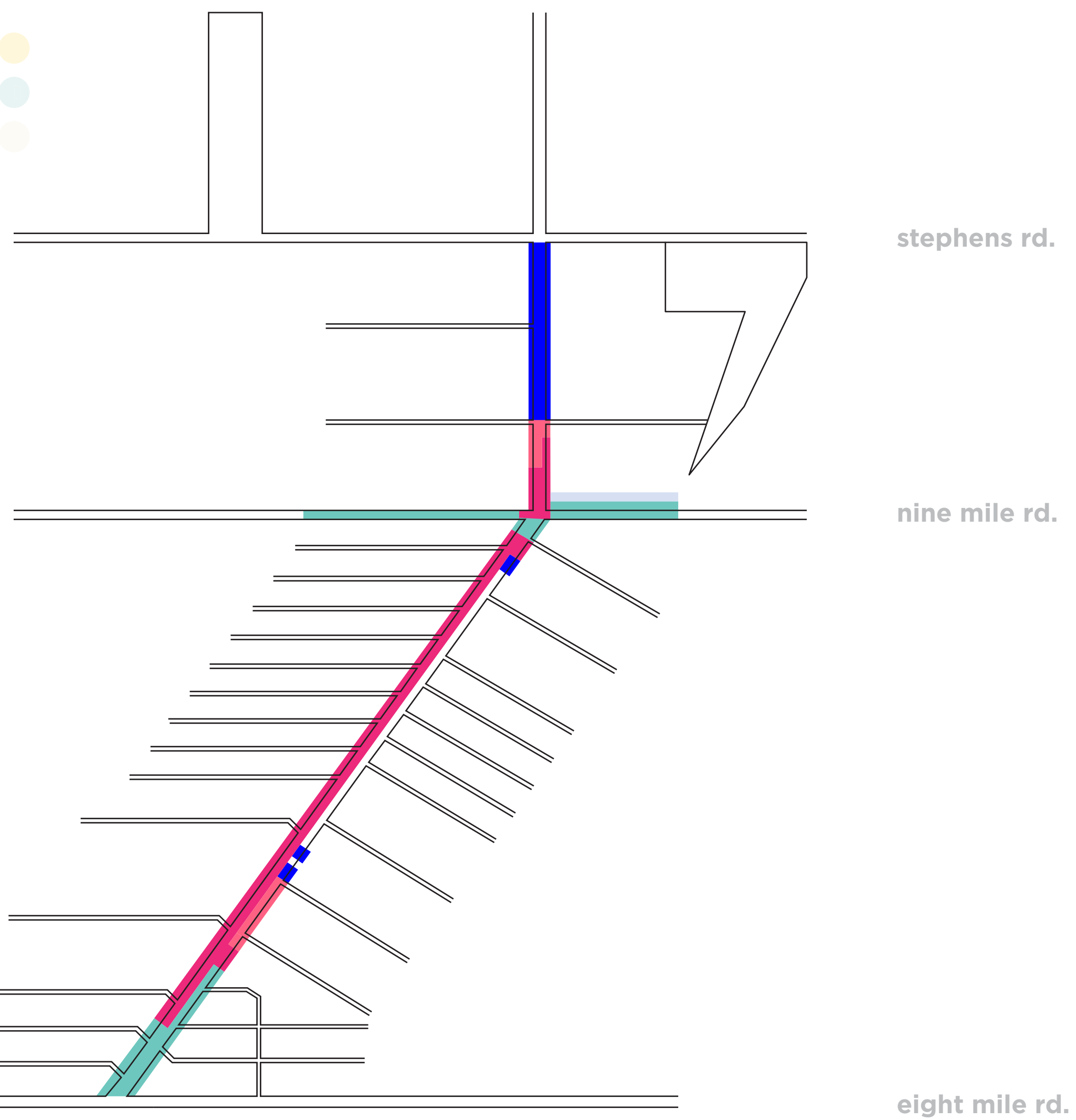

Site Plan



-  Residential Multi-Family low rise
-  Community Business District
-  General Business District
-  Office Service District
-  Vehicle Service District

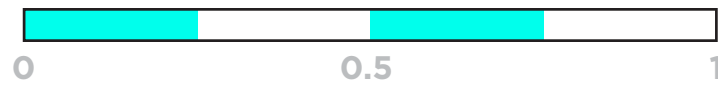

kilometers



stephens rd.

nine mile rd.

eight mile rd.



Why Kelly Road?

System Diagram





Parkpointe

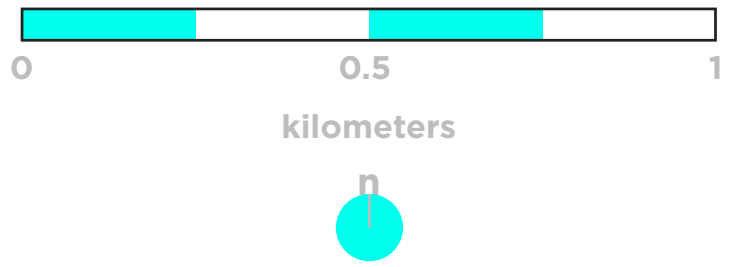
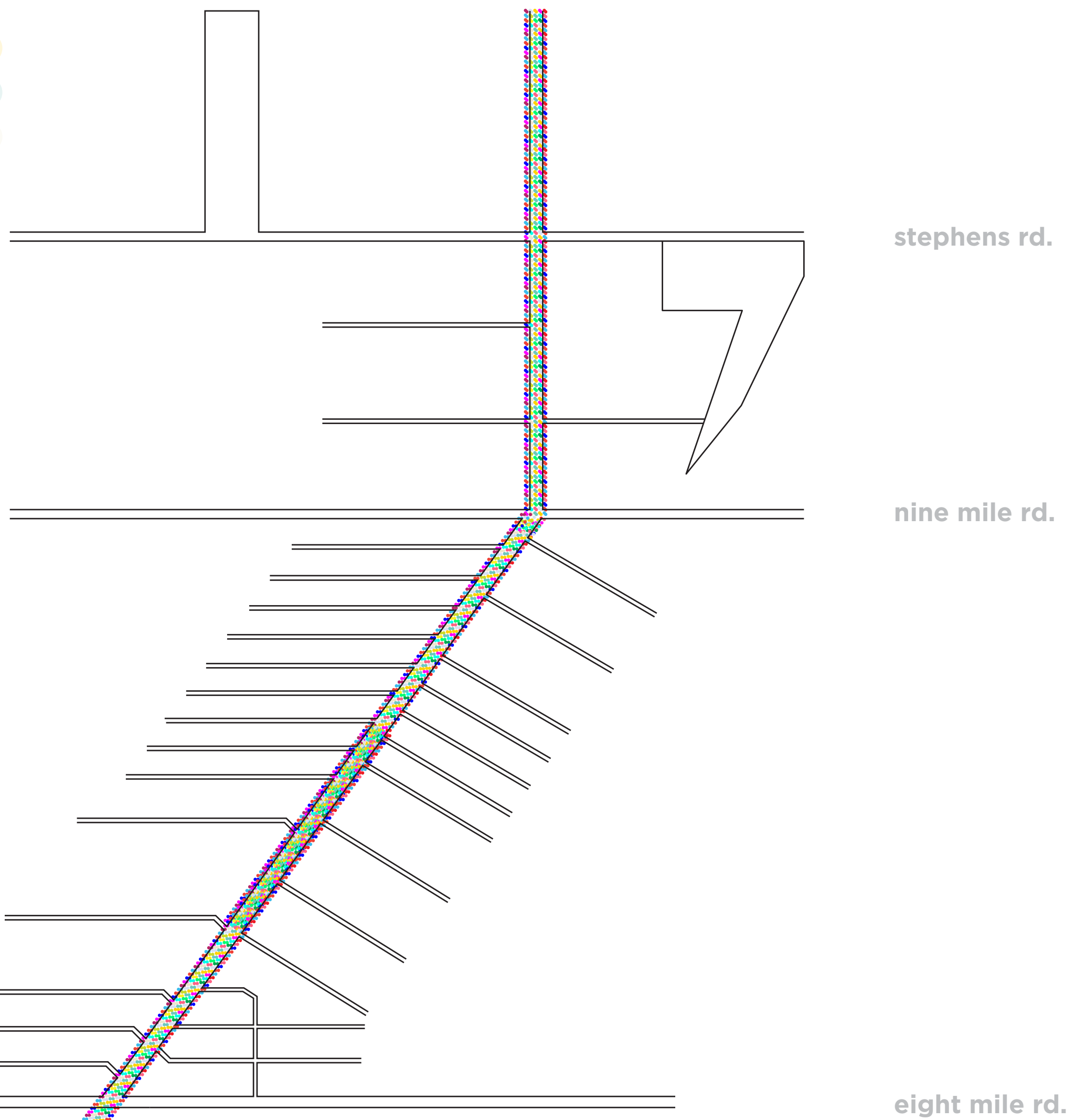

kilometers

n





Phase 1

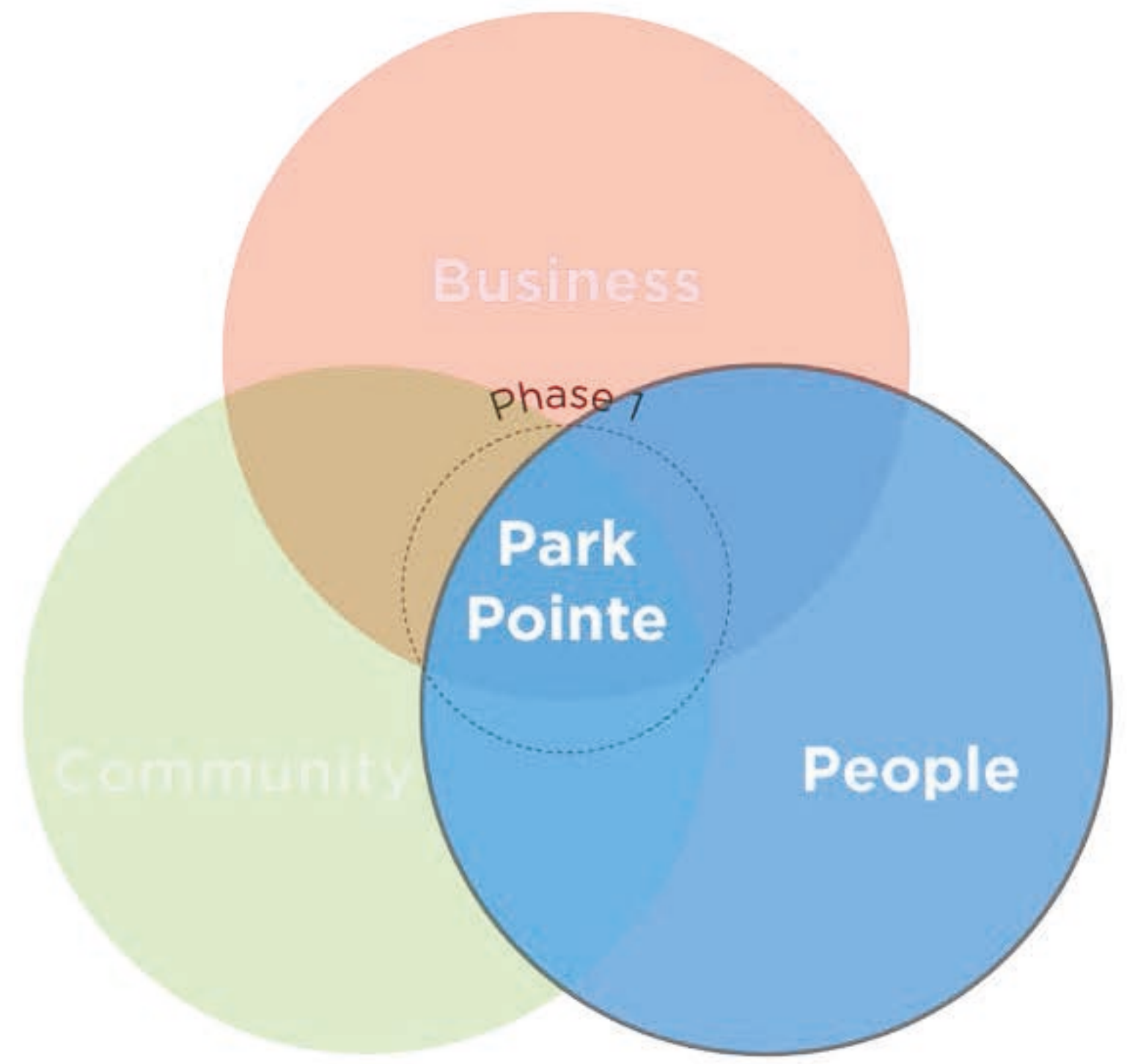

Tools uses P1

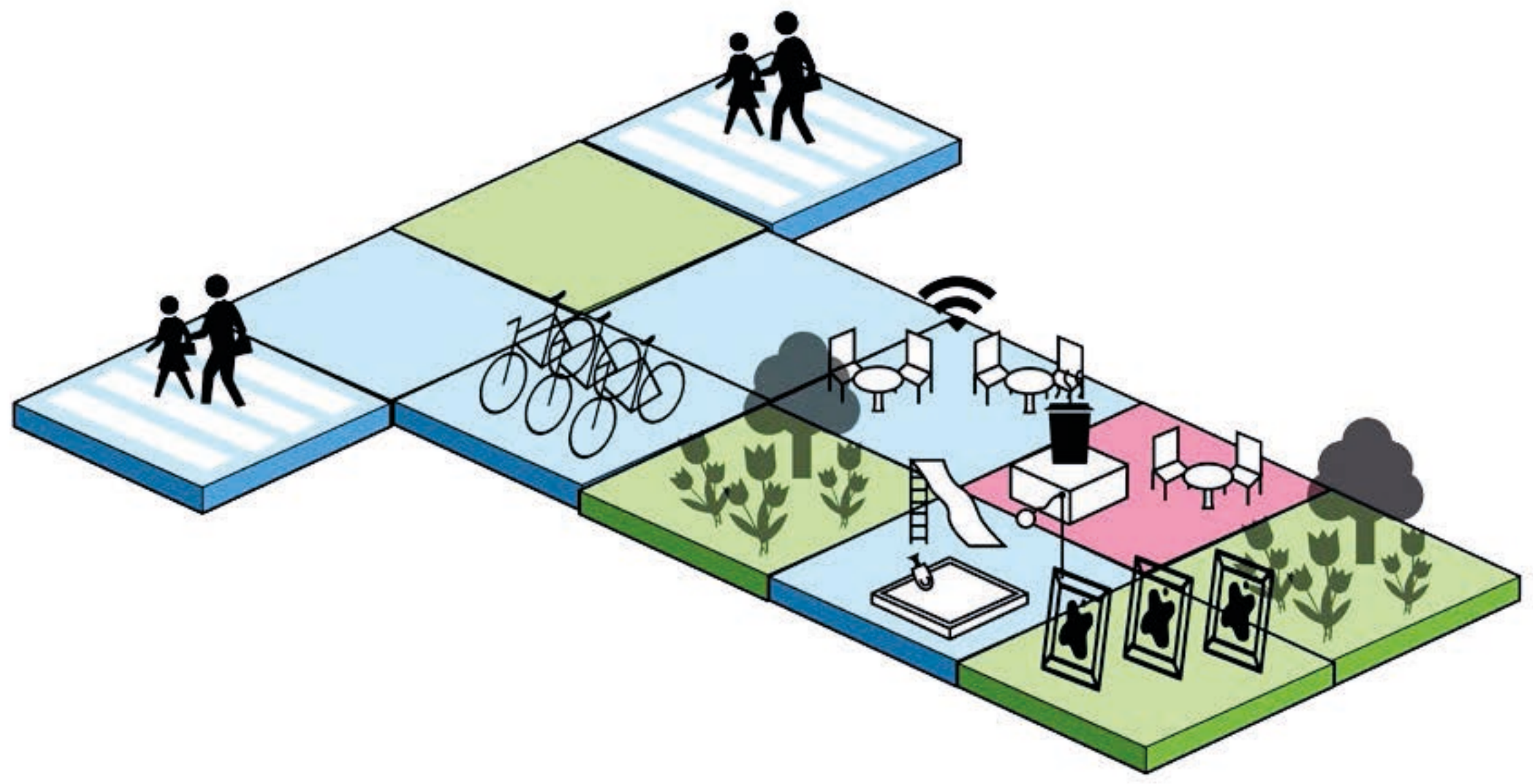

Tools uses P1



Wi-fi Spot



Playground



Coffee Shop



Bicycle Parking



Park / Garden



Arts & Culture

Phase 2

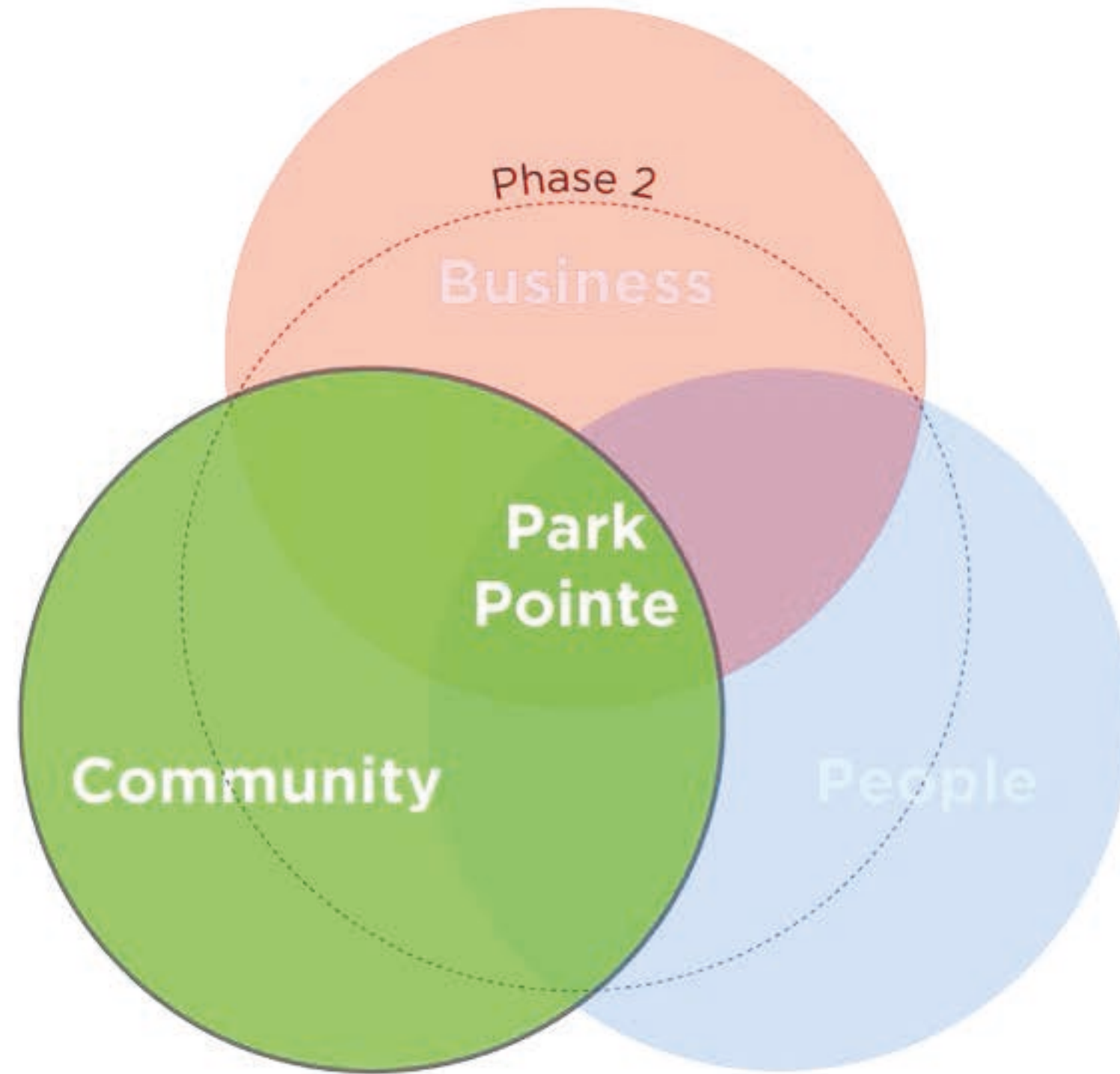

Tools uses P2



Wi-fi Spot



Playground

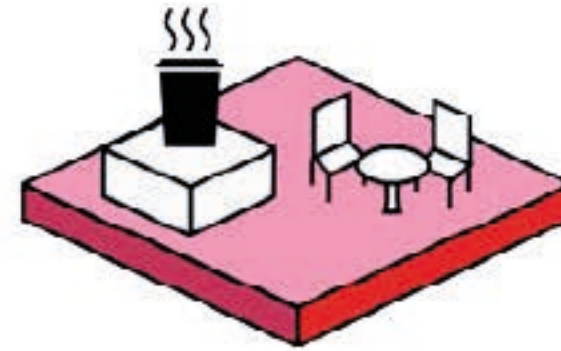

Coffee Shop



Bicycle Parking

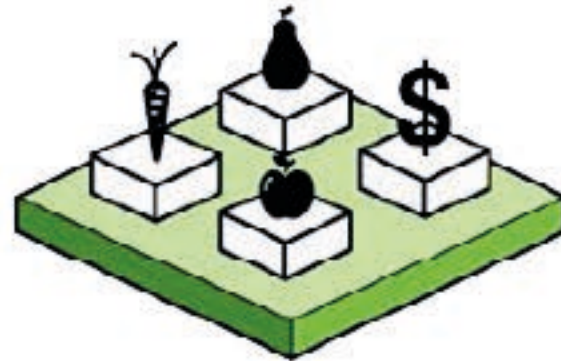

Farmers Market

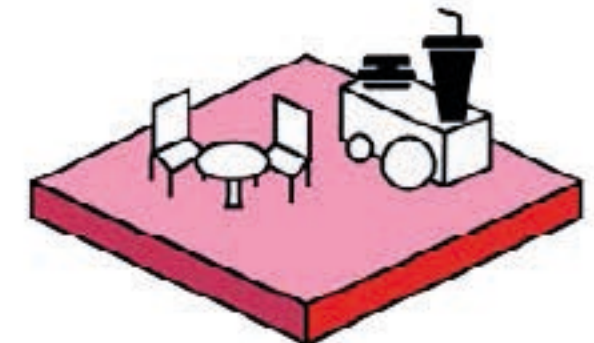

Food Stop



Events & Festivals



Park / Garden



Arts & Culture

Tools uses P2

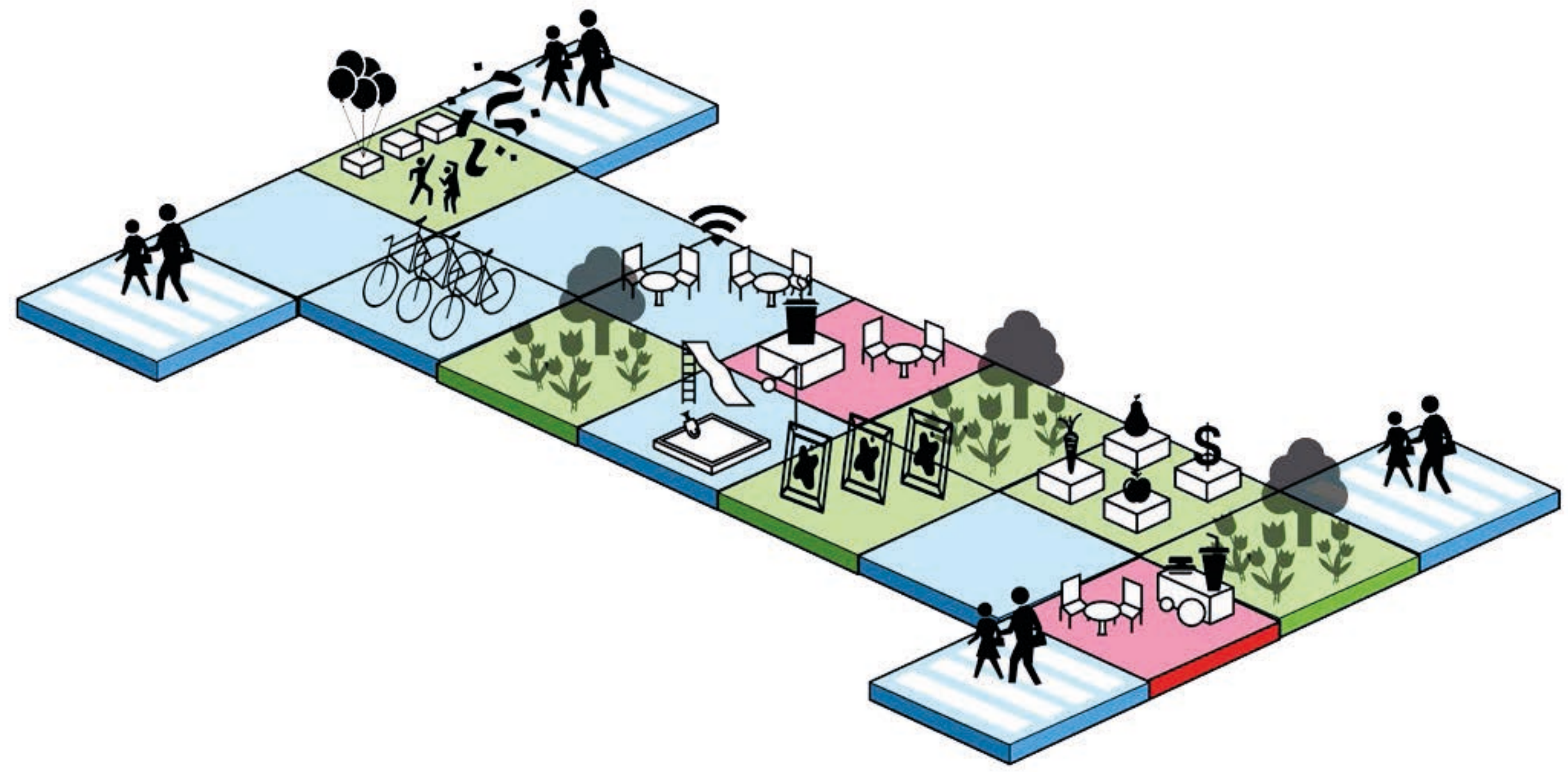

Phase 3

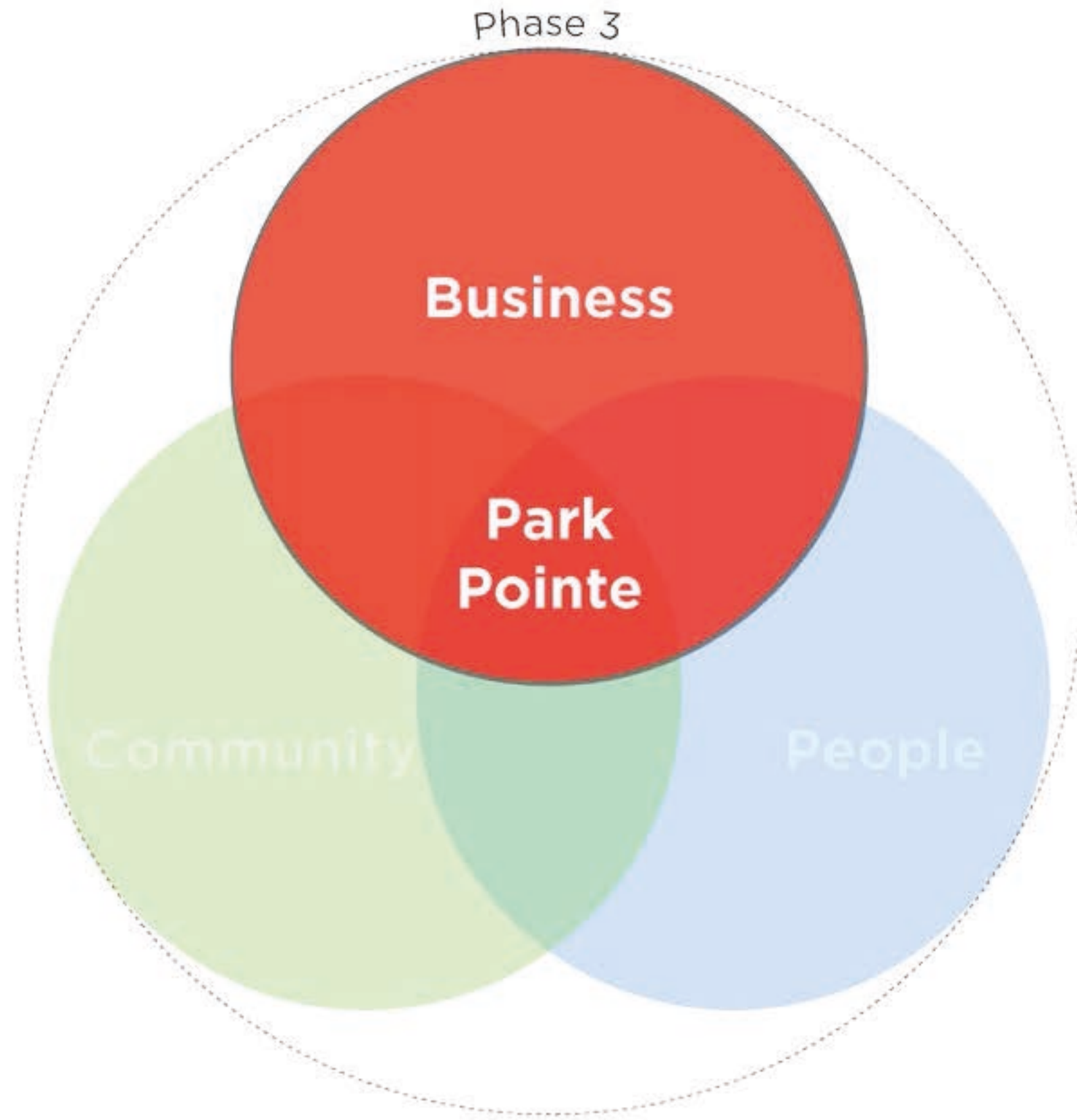

Tools uses P3



Wi-fi Spot



Playground



Coffee Shop

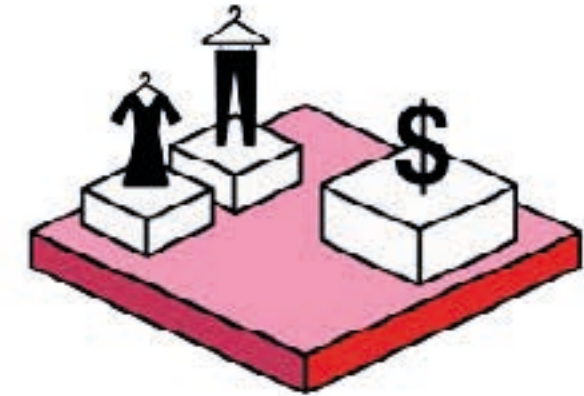

Clothing Shop



Bicycle Parking

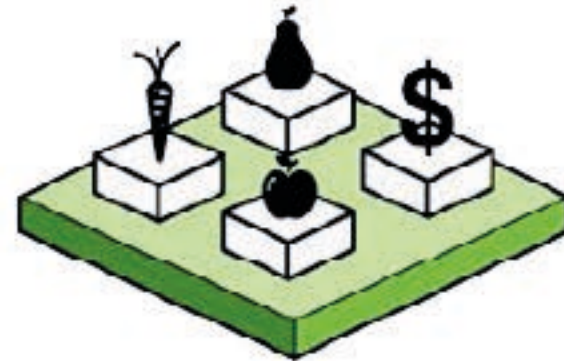

Farmers Market



Gift Shop

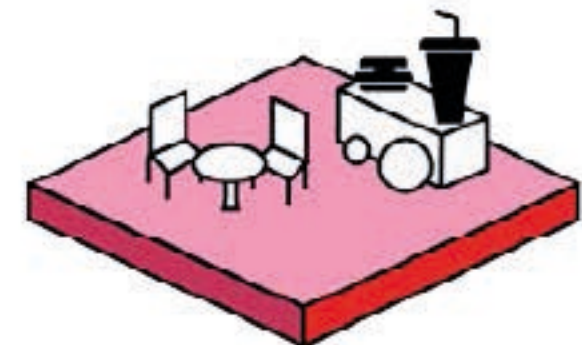

Food Stop



Events & Festivals



Park / Garden

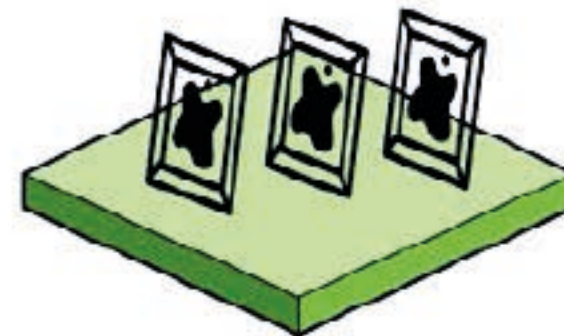

Arts & Culture



Shopping

Tools uses P3

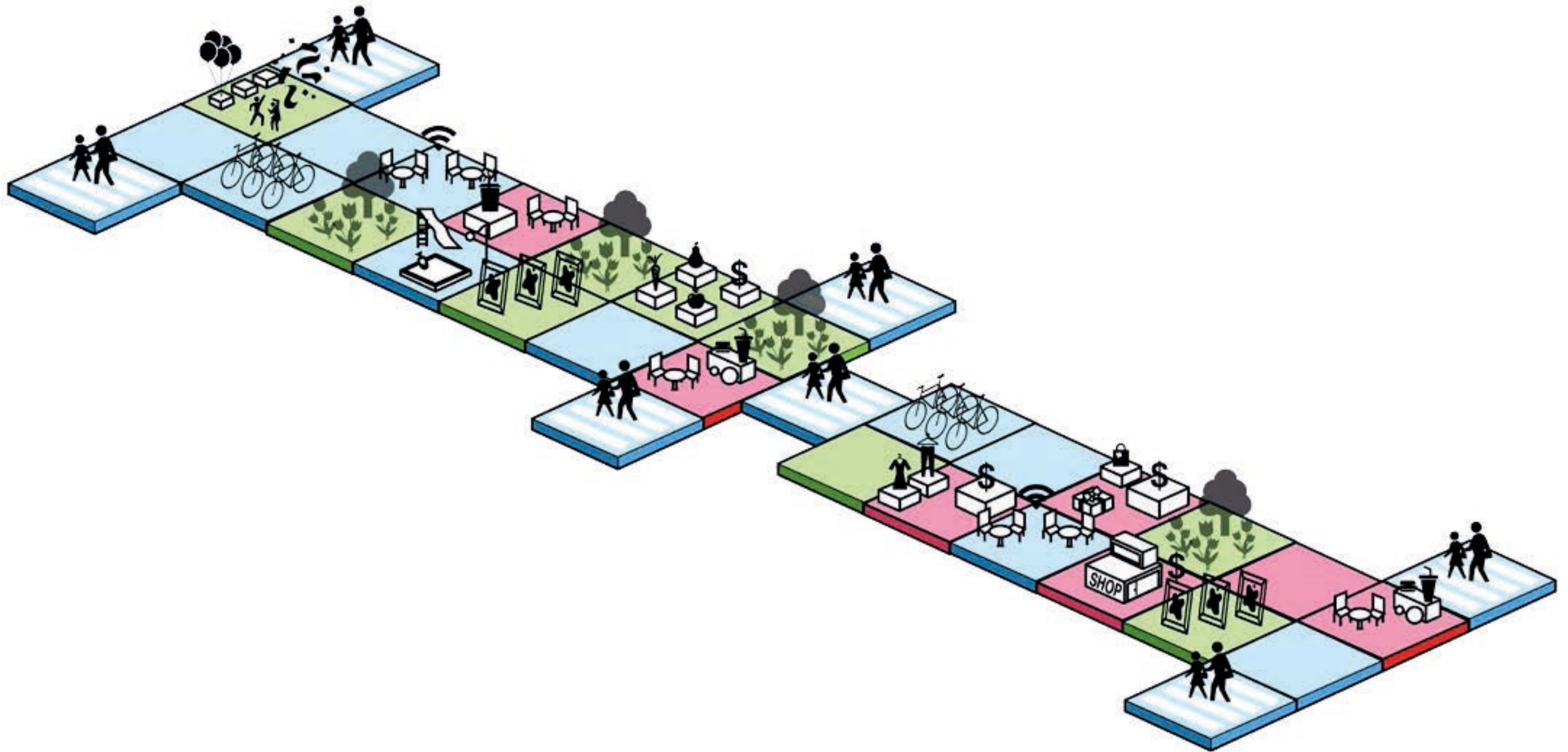

Section



Phase 1

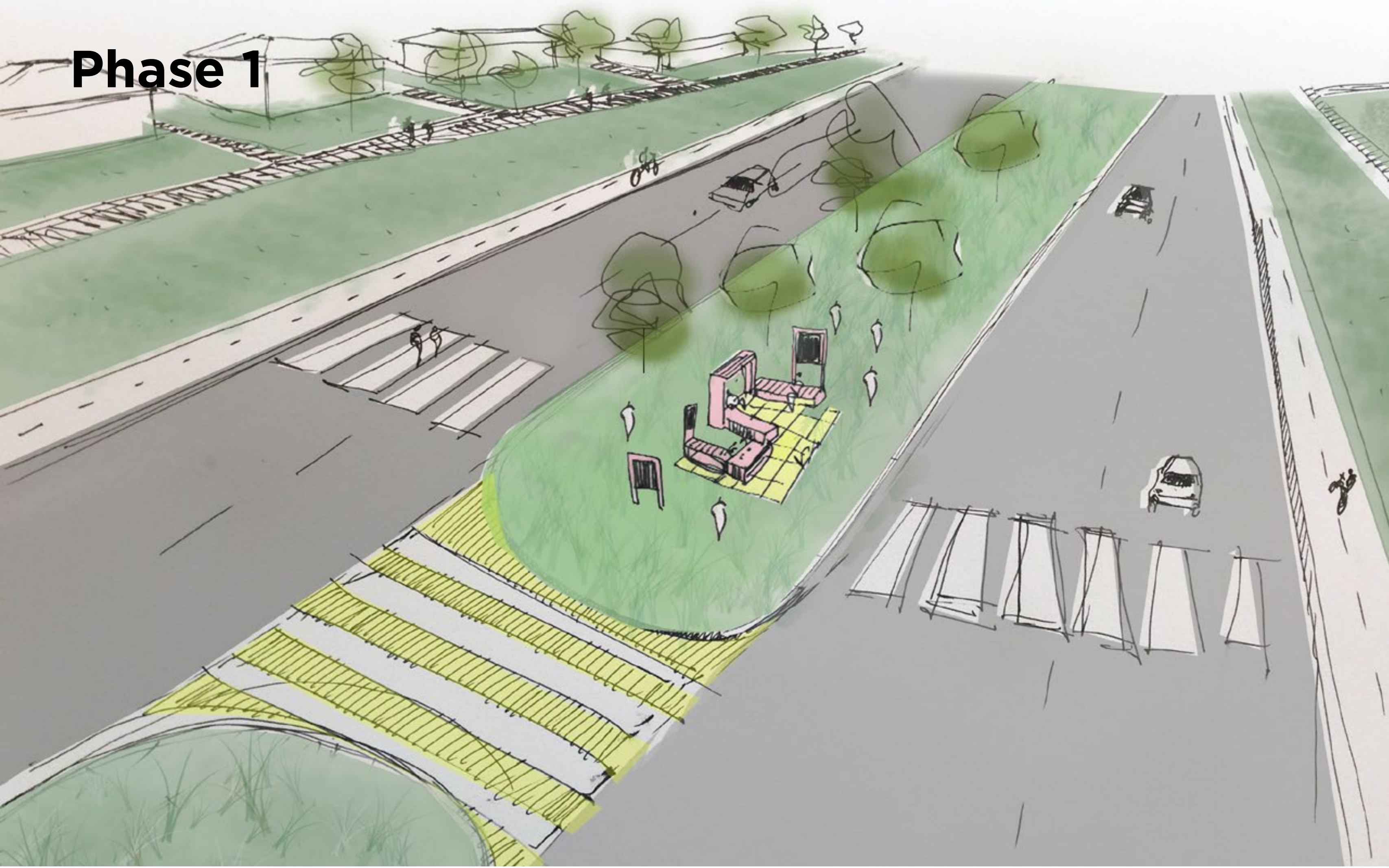

Phase 2



Phase 3







What can we do today?

Prototype



Shop stand

Material: Recycled Plastic
Dim.: 98"x90"x40"

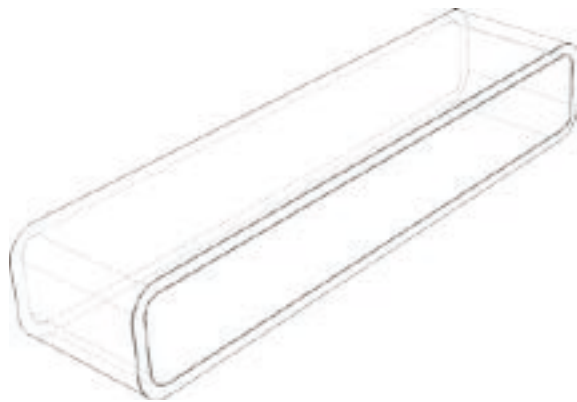

Seating

Material: Recycled Plastic
Dim.: 90"x24"x18"

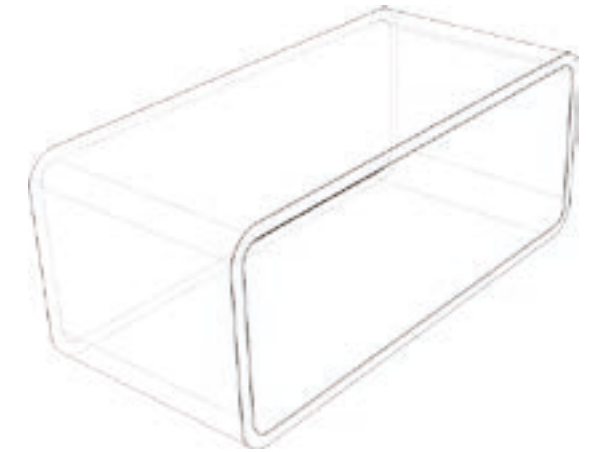
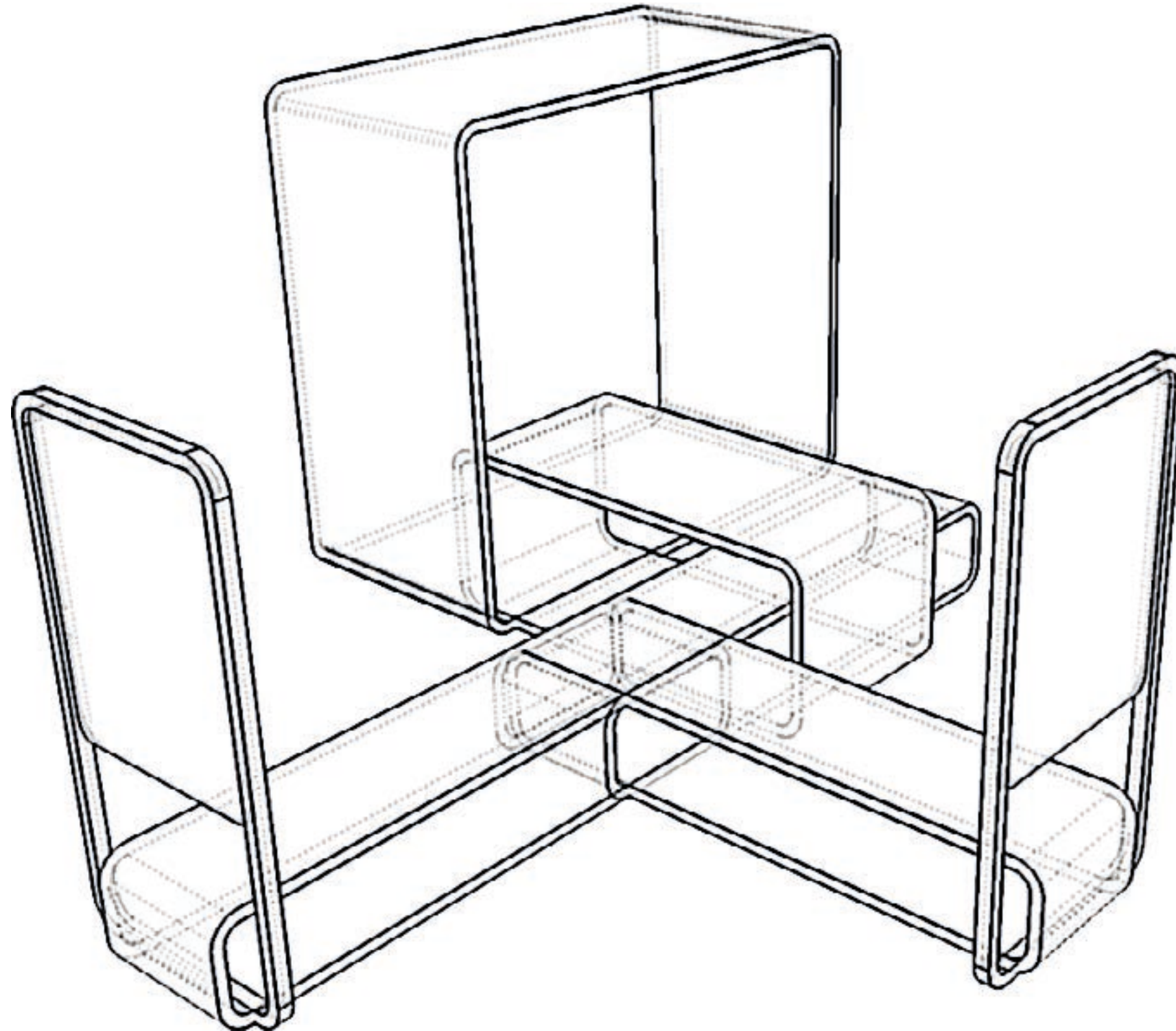

Table

Material: Recycled Plastic
Dim.: 35"x70"x32"



Communication/Play

Material: Recycled Plastic
Dim.: 2"x40"x80"

Phase 1

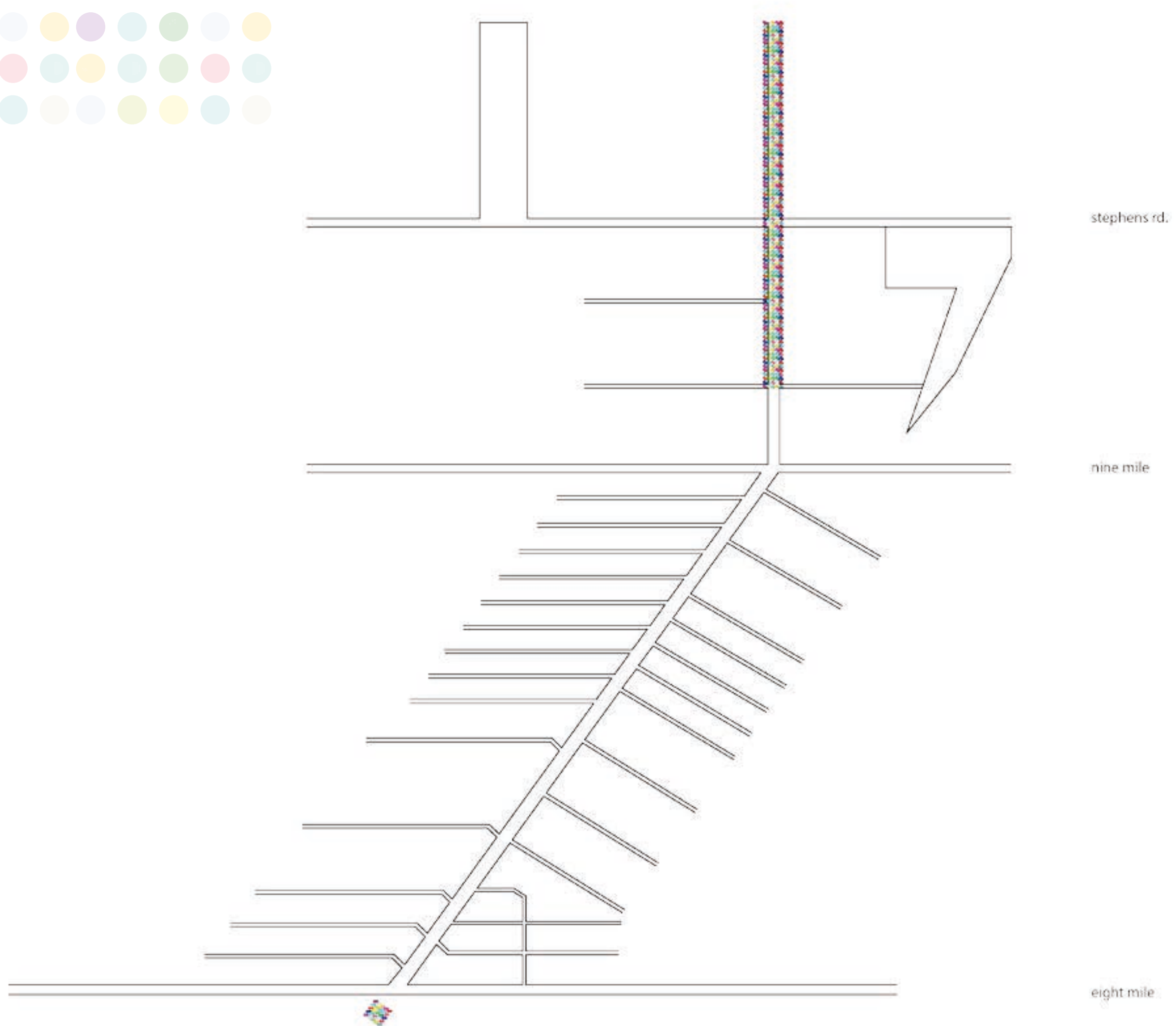

Phase 2

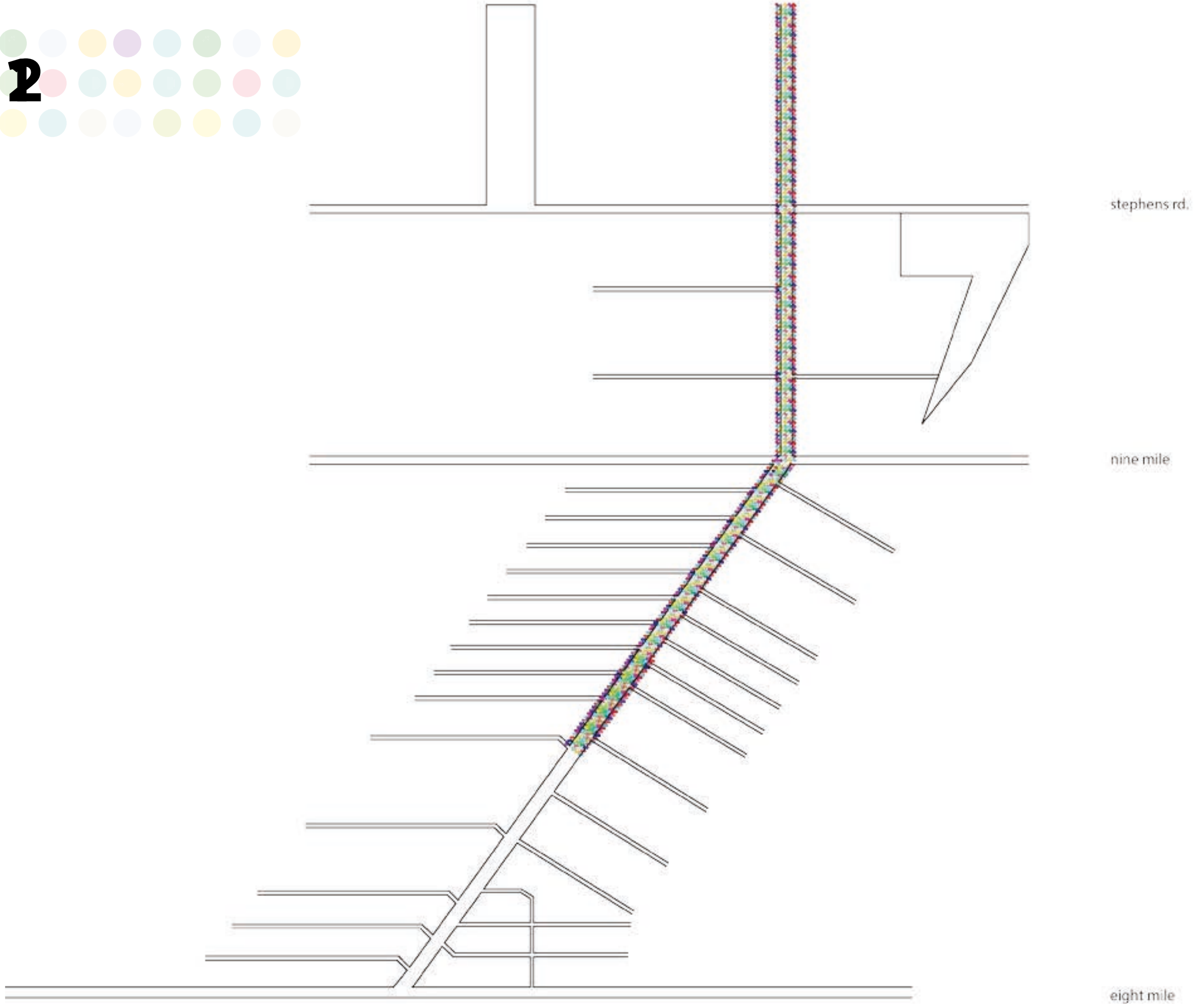

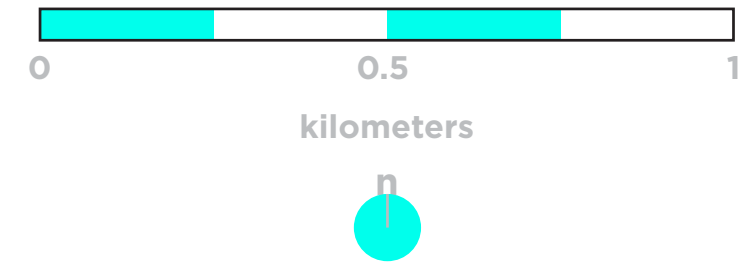
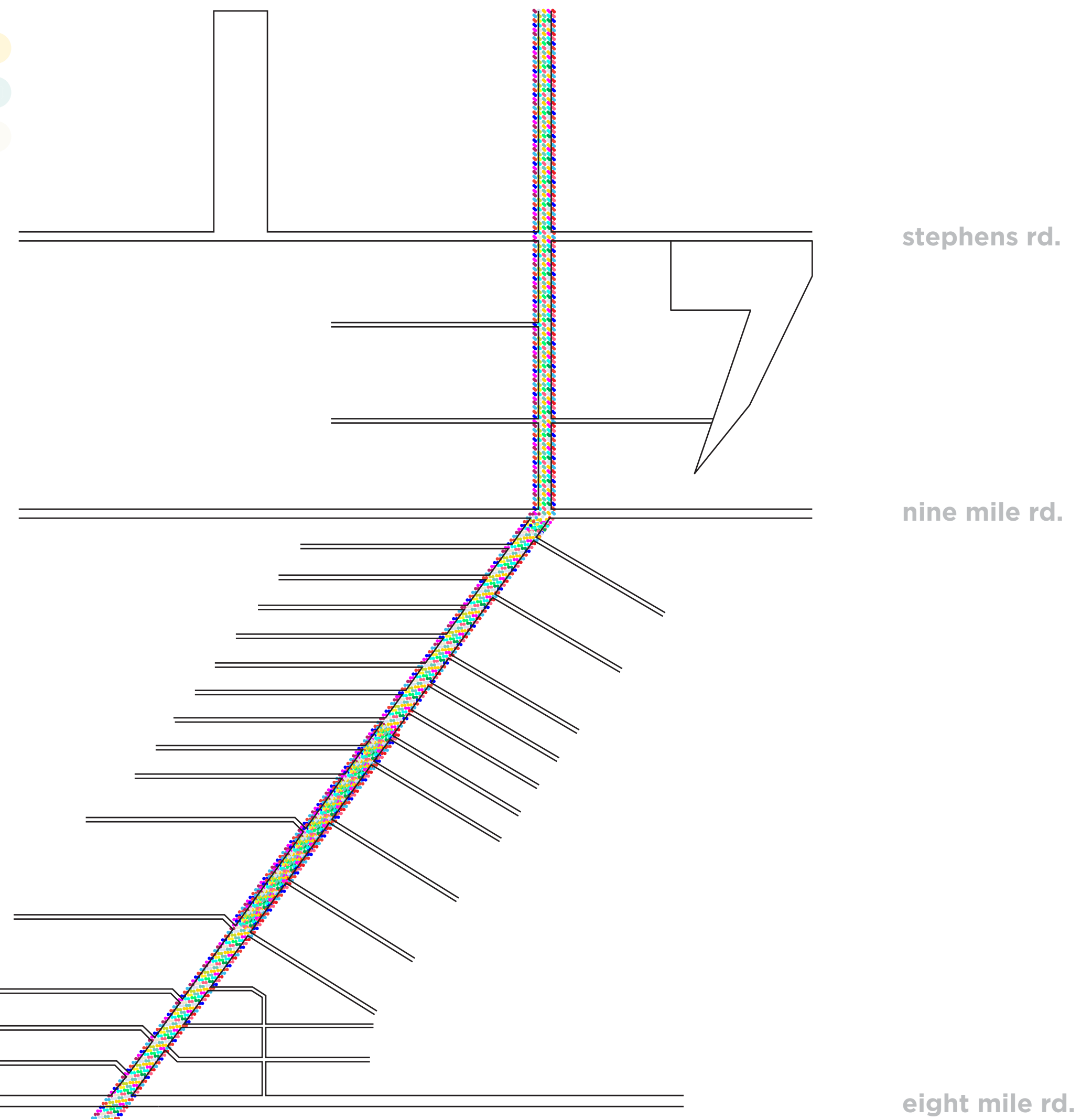

Thank you

#parkpointe

